

[www.wackergroup.com](http://www.wackergroup.com)

0162089en	008
1107	

## Mobile Generator

**G 50**

**G 70**

**G 85**



**OPERATOR'S MANUAL**



0 1 6 2 0 8 9 E N

**6. Technical Data**

**6.1 Engine Data**

Item Number:	<b>G 50</b> 0009366 0009467 0620001 Rev. 112 & lower	<b>G 70</b> 0009367 0009468 0620002 Rev. 113 & lower	<b>G 70</b> 0620350 0620352	<b>G 85</b> 0009369 0009459 0620003 Rev. 114 & lower
<b>Engine</b>				
Engine make / type	John Deere / 4.5L			
Model	4045DF270	4045TF270	4045TF285	4045TF275
Number of cylinders	4			
Displacement l (in <sup>3</sup> )	4.5 (274.6)			
Engine speed rpm	1800			
Power @ 1800 rpm kW/Hp	50/67	74.5/100	74/99	84.2/113
Coolant capacity l (qts.)	22.7 (24)	22.7 (24)	26.5 (28)	22.7 (24)
Oil capacity l (qts.)	15 (15.9)			
Battery Volts/CCa	12/720			
Fuel type	Diesel			
Fuel tank capacity l (gal.)	337 (89)			
Fuel consumption, continuous load l/hr (gal./hr)	12.5 (3.3)	17.4 (4.6)	18.7 (4.9)	21.2 (5.6)
Running time, continuous load Hours	27	19.3	18.2	16

Item Number:	<b>G 50</b> 0620001 Rev. 113 & above	<b>G 70</b> 0620002 Rev. 114 & above	<b>G 70</b> 0620351	<b>G 85</b> 0620003 Rev. 115 & above
<b>Engine</b>				
Engine make / type	John Deere / 4.5L			
Model	4045DF270	4045TF270	4045TF285	4045TF275
Number of cylinders	4			
Displacement l (in <sup>3</sup> )	4.5 (274.6)			
Engine speed rpm	1800			
Power @ 1800 rpm kW/Hp	50/67	74.5/100	74/99	84.2/113
Coolant capacity l (qts.)	22.7 (24)	22.7 (24)	26.5 (28)	22.7 (24)
Oil capacity l (qts.)	15 (15.9)			
Battery Volts/CCa	12/1000			
Fuel type	Diesel			
Fuel tank capacity l (gal.)	337 (89)			
Fuel consumption, continuous load l/hr (gal./hr)	12.5 (3.3)	17.4 (4.6)	18.7 (4.9)	21.2 (5.6)
Running time, continuous load Hours	27	19.3	18.2	16

**6.2 Generator Data**

Item Number:	<b>G 50</b> 0009366 0009467 0620001	<b>G 70</b> 0009367 0009468 0620002	<b>G 70</b> 0620350 0620351 0620352	<b>G 85</b> 0009369 0009459 0620003
<b>Generator</b>				
Make/Type	Mecc Alte / Brushless			
Model	ECO32-3S/4	ECO32-2L/4	ECO32-3L/4	ECO32-3L/4
Generator speed rpm	1800			
Voltage selector switch	3 position			
AC voltages available	120/240 zig-zag 120/208 low-wye 277/480 Hi-wye			
Frequency	60 Hz			
Power factor 1Ø 3Ø	1.0 0.8			
Voltage regulation	±1.00%			
Insulation class	H			
Sound level at 7 m (23 ft.) dB(A)	66	68	69	
AC receptacles	2 duplex, 3 twist-lock			
1Ø 120 GFI duplex Amps	2-20			
1Ø 120/240 V twist lock Amps	1-30A 2-50A			
Standby Output kW/ kVA	42/53	63/79	74/92	
Continuous Output kW/ kVA	38/48	58/72	67/84	
Main breaker Amps	175	225	250	

**6.3 Trailer and Skid Data**

Item Number:	G 50 0009366	G 50 0009467 0620001	G 70 0009367	G 70 0009468 0620002	G 70 0620350	G 70 0620351 0620352	G 85 0009369	G 85 0009459 0620003
<b>Trailer and Skid</b>								
Dry weight of skid kg (lbs.)	1432 (3157)	1473 (3247)	1509 (3328)	1550 (3418)	1608 (3544)	1648 (3634)	1580 (3484)	1621 (3574)
Operating weight of skid kg (lbs.)	1720 (3793)	1761 (3883)	1798 (3964)	1839 (4054)	1896 (4180)	1937 (4270)	1868 (4120)	1909 (4210)
Trailer weight kg (lbs.)								
Single axle								
Tandem axle	499 (1100)							
GVWR kg (lbs.)								
Single axle								
Tandem axle	2722 (6000)							
Surge brakes Fluid type	DOT3							
Tires size	ST225/75D-15D							

6.4 Dimensions

mm (inches)

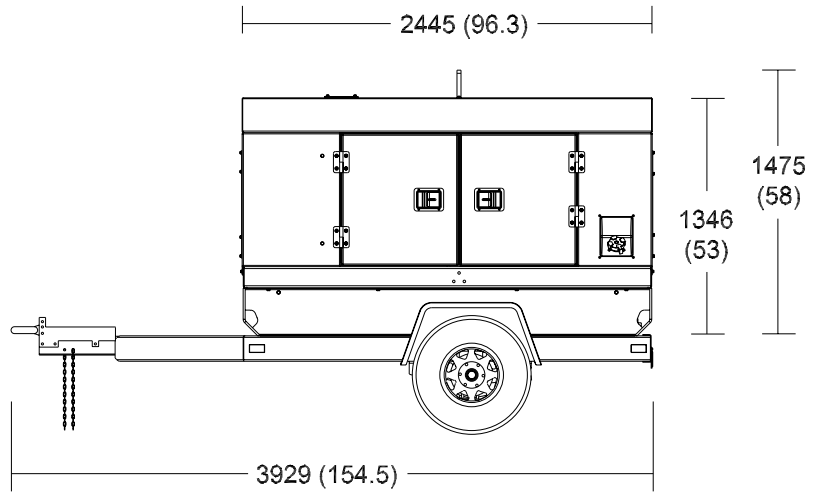
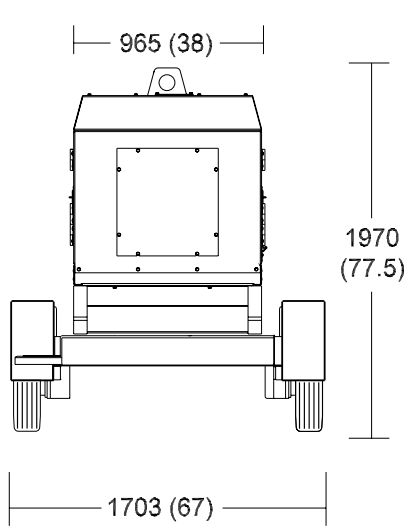

wc\_gr002606